

ARINC 429 Protocol Tutorial



Copyrights

Copyright © 2000-2005 ZHHKTECH Co.ltd.
All rights reserved.

This document may not, in whole or part, be; copied; photocopied; reproduced; translated; reduced or transferred to any electronic medium or machine-readable form without prior consent in writing from Shaanxi Zhenghong Aviation Science and Technology Electronic Co., Ltd



ARINC Protocol Tutorial

Document Date: 23 May, 2005
Document Revision: 1.0

ZHHKTECH Co.ltd
#13 FengHui South Rd
Xi'an 710077 China
029-84288198
029-84288198 (fax)
info@zhktech.com (email)
<http://www.zhktech.com>
<http://www.1553b-arinc429.com>



Contents

Chapter 1	ARINC 429 Tutorial	
	Introduction.....	1
	About ARINC.....	2
	What is ARINC 429?	2
	ARINC 429 Usage	3
	ARINC 429 Electrical Characteristics	3
	Protocol	5
	Bit Timing and Slew Rate.....	6
	ARINC 429 Word Format.....	7
	Parity.....	7
	SSM.....	7
	Data.....	8
	SDI.....	8
	Label.....	8
	Transmission Order.....	8
	ARINC 429 Data Types	9
	BCD Data Encoding.....	9
	BNR Data Encoding.....	9
	Mixed Formats	10
	Discrete Data Formats.....	11
	Maintenance Data.....	12
	Data Translation Method.....	12
	Bit Oriented Protocols	15
Chapter 2	ARINC 429 Testing	
	Test Equipment.....	18
Chapter 3	Other ARINC Protocols	
	ARINC 419.....	19
	ARINC 453.....	20

ARINC 561/568.....	20
ARINC 573.....	20
ARINC 575.....	21
ARINC 582.....	21
ARINC 615.....	21
ARINC 629.....	22
ARINC 708.....	22
ARINC 717.....	22

Appendix A

References

List of References	23
--------------------------	----

Table of Figures

Figure 1. ARINC 429 Bit Encoding Example	5
Figure 2. Slew Rates and Bit Timing Diagram.....	6
Figure 3. Generalized ARINC Word Format.....	7
Figure 4. Generalized BCD Word Format.....	9
Figure 5. BCD Word Format Example	9
Figure 6. Generalized BNR Word Format.....	10
Figure 7. Example BNR Encoding.....	10
Figure 8. File Transfer Scheme Version 1 (no Windows).....	16
Figure 9. ARINC 561 6-Wire Bit Encoding.....	20
Figure 10. Harvard Bi-phase Bit Encoding.....	21

List of Tables

Table 1. Partial List of Equipment IDs	4
Table 2. ARINC 429 Characteristic Summary	5
Table 3. ARINC Bit Characteristics.....	6
Table 4. SSM Codes for BCD data	7
Table 5. SSM Codes for BNR data	7
Table 6. Dedicated Discrete Example	11
Table 7. Examples of BCD Labels.....	13
Table 8. Examples of BNR Labels.....	13
Table 9. Equipment IDs for Tables 6 and 7	13
Table 10. Message Sequence for Label 241	14
Table 11. Systems Using Bit Oriented Communications and Their Address Labels.....	17

ARINC 429 Protocol Tutorial

Introduction

This document provides an overview of ARINC 429 and other ARINC protocols. ARINC 429 is the most commonly used data bus for commercial and transport aircraft. This document explains the origins of the ARINC Corporation, the data bus specification and where ARINC 429 is used. Then it summarizes the principal electrical and data characteristics, which are defined in the specification.

This document is not a complete description of ARINC 429. It is intended only as a brief tutorial and isn't meant to replace the complete specification, which can be purchased from ARINC (see Appendix A, "References" for contact information).

ARINC 429 employs unidirectional transmission of 32 bit words over two wire twisted pairs using bipolar RZ format. This tutorial includes charts illustrating slew times and bit timing. It describes the five fields in each word and explains the use of labels. Messages are repeated at specified intervals with typical applications sending groups or frames of messages. Examples are given of the commonly used word formats such as BNR, BCD, Discrete data, and other formats. Also explained is a newer bit-oriented protocol, sometimes called the Williamsburg Protocol, which has been introduced to provide an improved method of transmitting files of data. Additionally, the document includes a brief explanation of other ARINC specifications, such as 419, 561, 573, 582, 615, and 717.

Frequent references are made to ARINC Specification 429 and many examples are taken from it. This tutorial is intended to introduce you to the subject. Individuals needing more detail should obtain a copy of the specification from ARINC and also should consider consulting other sources identified in the list of references.

This document has been prepared by Condor Engineering Incorporated for use by its employees and customers. Condor is a full-service manufacturer of Test, Simulation, and Interface products for avionics data buses. The hardware and software can be used to monitor or simulate data bus

messages for analyses and for simulating bus operation. To learn about the full line of Condor products, visit our Web site or contact us by phone or fax. Information can also be obtained via e-mail. See the Copyrights page of this manual for the latest contact information. Detailed installation and user manuals are provided with each product, and demonstration software is available free of charge.

About ARINC

Aeronautical Radio, Incorporated (ARINC) is a major company that develops and operates systems and services to ensure the efficiency, operation, and performance of the aviation and travel industries. It was organized in 1929 by four major airlines to provide a single licensee and coordinator of radio communications outside the government. Only airlines and aviation-related companies can be shareholders, although all airlines and aircraft can use ARINC's services. It is now a \$280 million company with headquarters in Annapolis, Maryland and over 50 operating locations worldwide. The company has two major thrusts:

- .. Communications and information processing services for the aviation and travel industry.
- .. System engineering, development and integration for government and industry.

ARINC has provided leadership in developing specifications and standards for avionics equipment, and one of these specifications is the focus of this tutorial. Industry-wide committees prepare the specifications and standards. ARINC Specification 429 was developed and is maintained by the Airlines Electronic Engineering Committee (AEEC) comprising members that represent airlines, government, and ARINC.

The General Aviation Manufacturers Association (GAMA) in Washington, D.C. also maintains a specification document with ARINC 429 labels: "ARINC 429 General Aviation Subset".

What is ARINC 429?

ARINC 429 is a specification, which defines how avionics equipment and systems should communicate with each other. They are interconnected by wires in twisted pairs. The specification defines the electrical and data characteristics and protocols, which are used. ARINC 429 employs a unidirectional data bus standard known as Mark 33 Digital Information Transfer System (DITS). Messages are transmitted at a bit rate of either 12.5 or 100 kilobits per second to other system elements, which are monitoring the bus messages. Transmission and reception is on separate ports so that many wires may be needed on aircraft, which use a large number of avionics systems.

ARINC 429 Usage

ARINC 429 has been installed on most commercial transport aircraft including; Airbus A310/A320 and A330/A340; Bell Helicopters; Boeing 727, 737, 747, 757, and 767; and McDonnell Douglas MD-11. Boeing is installing a newer system specified as ARINC 629 on the 777, and some aircraft are using alternate systems in an attempt to reduce the weight of wire needed and to exchange data at a higher rate than is possible with ARINC 429. The unidirectional ARINC 429 system provides high reliability at the cost of wire weight and limited data rates. Military aircraft generally use a high-speed, bi-directional protocol specified in Military Specifications MIL-STD-1553.

Each aircraft may be equipped with different electronic equipment and systems needing interconnection. A large amount of equipment may be involved depending on the aircraft. These are identified in the specification and are assigned digital identification numbers called Equipment ID. A partial list of equipment identified in ARINC Specification 429-15 can be found in Table 1 along with their digital addresses.

The specification also identifies a number of systems, which are capable of interchanging files of data in a bit-oriented format. Such files may require the transmission of a number of messages in sequence. Systems capable of bit-oriented communications and their addresses are listed in Table 10. The SAL is used to identify the recipient of a bit oriented message.

ARINC 429 Electrical Characteristics

An ARINC 429 data bus uses two signal wires to transmit 32 bit words. Transmission of sequential words is separated by at least 4 bit times of NULL (zero voltage). This eliminates the need for a separate clock signal wire. That's why this signal is known as a self-clocking signal.

The nominal transmission voltage is 10 ± 1 volts between wires (differential), with either a positive or negative polarity. Therefore, each signal leg ranges between +5V and -5V. If one leg is +5V, the other is -5V and vice versa. One wire is called the "A" (or "+" or "HI") side and the other is the "B" (or "-" or "LO") side. This is known as bipolar return-to-zero (BPRZ) modulation. The composite signal state may be one of three levels:

- .. HI which should measure between 7.25 and 11 volts between the two wires (A to B).
- .. NULL which should be between 0.5 and -0.5 (A to B).
- .. LO which should be between -7.25 and -11 volts (A to B).

The received voltage depends on line length and the number of receivers connected to the bus. No more than 20 receivers should be connected to a single bus. Since each bus is unidirectional, a system needs to have its own transmit bus if it is required to respond or to send messages.

Table 1. Partial List of Equipment IDs

Eq. ID	Equipment Type	Eq. ID	Equipment Type
001	Flight Control Computer (701)	029	ADDCS (729) and EICAS
002	Flight Management Computer (702)	02A	Thrust Management Computer
003	Thrust Control Computer (703)	02B	Perf. Nav. Computer System (Boeing 737)
004	Inertial Reference System (704)	02C	Digital Fuel Gauging System (A310)
005	Attitude and Heading Ref. System (705)	02D	EPR Indicator (Boeing 757)
006	Air Data system (706)	02E	Land Rollout CU/Landing C & LU
007	Radio Altimeter (707)	02F	Full Authority EEC-A
008	Airborne Weather Radar (708)	030	Airborne Separation Assurance System
009	Airborne DME (709)	031	Chronometer (731)
00A	FAC (A310)	032	Passenger Entertain. Tape Reproducer (732)
00B	Global Positioning System	033	Propulsion Multiplexer (PMUX) (733)
00D	AIDS Data Management System	034	Fault Isolation and Detection System (734)
010	Airborne ILS Receiver (710)	035	TCAS (735)
011	Airborne VOR Receiver (711)	036	Radio Management System (736)
012	Airborne ADF System (712)	037	Weight and Balance System (737)
016	Airborne VHF COM Receiver (716)	038	ADIRS (738)
017	DEFDARS-AIDS (717)	039	MCDU (739)
018	ATC Transponder (718)	03A	Propulsion Discrete Interface Unit
019	Airborne HF/SSB System (719)	03B	Autopilot Buffer Unit
01A	Electronic Supervisory Control	03C	Tire Pressure Monitoring System
01B	Digital Flap/Slat Computer (A310)	03D	Airborne Vibration Monitor (737/757/767)
01C	Engine Parameter Digitizer (Engine)	03E	Center of Gravity Control Computer
01D	A/P & F/D Mode Control Panel -757/767	03F	Full Authority EEC-B
01E	Performance Data Computer (Boeing)	040	Cockpit Printer
01F	Fuel Quantity Totalizer	041	Satellite Data Unit
020	DFS System (720)	046	CTU
023	Ground Proximity Warning Sys (723)	047	Digital Flight Data Recorder
024	ACARS (724)	----	additional items
025	Electronic Flt. Instruments (725)	----	“
026	Flight Warning Computer (726)	----	“
027	Microwave Landing System (727)	241	High Power Amplifier

The transmitting and receiving circuits must be designed for reliably sending and detecting the null transition between high and low states. The parameters vary with the type of operation as defined in Reference 2. The

slew rates and tolerances are shown in Figure 1 for both 100K and 12.5K data rates.

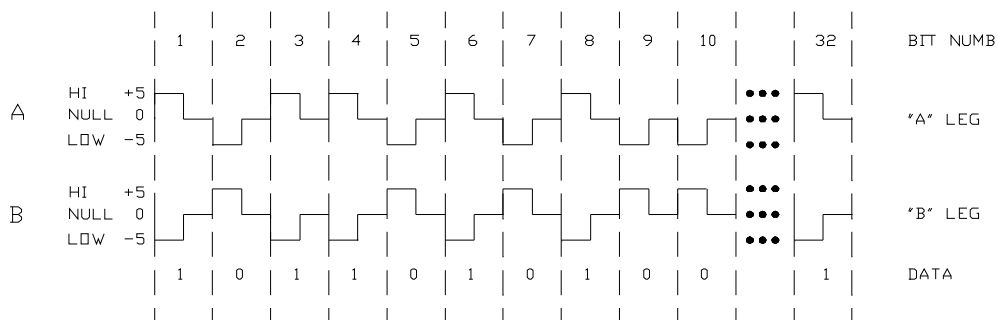

Figure 1. ARINC 429 Bit Encoding Example

Table 2 summarizes ARINC 429 characteristics.

Table 2. ARINC 429 Characteristic Summary

Electrical Characteristic	Value
Voltage Levels, each leg with respect to ground	+5V, 0V, -5V
Voltage Levels, Leg A with respect to Leg B	+10V, 0V, -10V
Bit Encoding	Bipolar Return to Zero
Word size	32 bits
Bit Rates	100K or 12.5K bits per second
High Speed Slew Rate	1.5 +/- 0.5 μsec
Low Speed Slew Rate	10 +/- 5 μsec

Protocol

ARINC 429 is a very simple, point-to-point protocol. There can be only one transmitter on a wire pair. The transmitter is always transmitting either 32-bit data words or the NULL state. There is at least one receiver on a wire pair; there may be up to 20.

In most cases, an ARINC message consists of a single data word. The label field of the word defines the type of data that is contained in the rest of the word.

Bit Timing and Slew Rate

The slew rate refers to the rise and fall time of the ARINC waveform. Specifically, it refers to the amount of time it takes the ARINC signal to rise from the 10% to the 90% voltage amplitude points on the leading and trailing edges of the pulse. See Figure 2.

Table 3. ARINC Bit Characteristics

Parameter	High Speed	Low Speed
Bit Rate	100K bits/second	12.5K-14.5K bits/second
Time Y (one bit)	10 $\mu\text{sec} \pm 2.5\%$	$1 \div (\text{bit rate}) \mu\text{sec} \pm 2.5\%$
Time X	5 $\mu\text{sec} \pm 5\%$	$Y/2 \mu\text{sec} \pm 5\%$
Pulse Rise Time	1.5 $\pm 0.5 \mu\text{sec}$	10 $\pm 5 \mu\text{sec}$
Pulse Fall Time	1.5 $\pm 0.5 \mu\text{sec}$	10 $\pm 5 \mu\text{sec}$

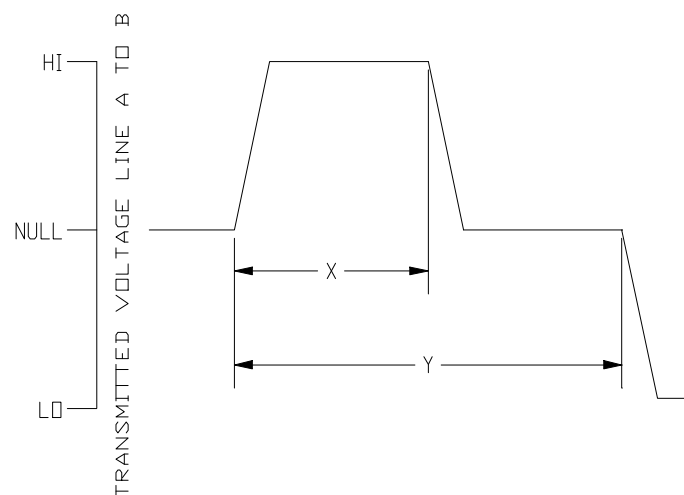

Figure 2. Slew Rates and Bit Timing Diagram

ARINC 429 Word Format

ARINC data words are always 32 bits and typically use the format shown in Figure 3 which includes five primary fields, namely Parity, SSM, Data, SDI, and Label. ARINC convention numbers the bits from 1 (LSB) to 32 (MSB).

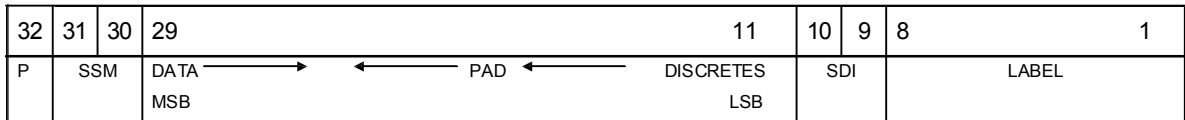

Figure 3. Generalized ARINC Word Format

Parity

The MSB is always the parity bit for ARINC 429. Parity is normally set to odd except for certain tests. Odd parity means that there must be an odd number of “1” bits in the 32-bit word that is insured by either setting or clearing the parity bit. For example if bits 1-31 contain an even number of “1” bits, bit 32 must be set to create ODD parity. On the other hand, if bits 1-31 contain an odd number of “1” bits, the parity bit must be clear.

SSM

Bits 31 and 30 contain the Sign/Status Matrix or SSM. This field contains hardware equipment condition, operational mode, or validity of data content. Applicable codes are shown in Table 4 and

Table 5.

Table 4. SSM Codes for BCD data

Bit		Meaning
31	30	
0	0	Plus, North, East, Right, To, Above
0	1	No Computed Data
1	0	Functional Test
1	1	Minus, South, West, Left, From, Below

Table 5. SSM Codes for BNR data

Bit		Meaning
31	30	

0	0	Failure Warning
0	1	No Computed Data
1	0	Functional Test
1	1	Normal Operation

Data

Bits 29 through 11 contain the data, which may be in a number of different formats. Some examples are provided later in the tutorial. There are also many non-standard formats that have been implemented by various manufacturers. In some cases, the data field overlaps down into the SDI bits. In this case, the SDI field is not used.

SDI

Bits 10 and 9 provide a Source/Destination Identifier or SDI. This is used for multiple receivers to identify the receiver for which the data is destined. It can also be used in the case of multiple systems to identify the source of the transmission. In some cases, these bits are used for data. ARINC 429 can have only one transmitter on a pair of wires, but up to 20 receivers.

Label

Bits 8 through 1 contain a label identifying the data type and the parameters associated with it. The label is an important part of the message and is described in more detail below. It is used to determine the data type of the remainder of the word and, therefore, the method of data translation to use. The various data types are described in detail below. Labels are typically represented as octal numbers.

Transmission Order

The least significant bit of each byte except the label is transmitted first, and the label is transmitted ahead of the data in each case. The order of the bits transmitted on the ARINC bus is as follows:

8, 7, 6, 5, 4, 3, 2, 1, 9, 10, 11, 12, 13 ... 32.

Note: When a 32-bit ARINC word is transmitted on the bus, in the case of the label, the most significant bit is transmitted first. This reverse order is in contrast to the transmission order of the other bits in the ARINC word.

ARINC 429 Data Types

All ARINC data is transmitted in 32 bit words. The data type may be Binary Coded Decimal (BCD), two's complement binary notation (BNR), Discrete Data, Maintenance Data and Acknowledgment, and ISO Alphabet #5 character data. In the newest versions, bit oriented packets of messages can be used to transmit files.

BCD Data Encoding

BCD, or binary-coded-decimal, is a common data format found in ARINC 429 and many other engineering applications. In this format, four bits are allocated to each decimal digit. A generalized BCD message is shown in Figure 4. Its data fields contain up to five sub-fields. The most significant sub-field contains only the bits, so that its maximum decimal value can be 7. If the maximum decimal value is greater than 7, bits 29 through 27 are padded with zeros and the second sub-field becomes the most significant. The example message in Figure 5 conveys the data that the DME distance is 25786 and has a positive sign. The specific equipment, numeric scale, and location of the decimal point are a function of the label and are discussed later.

32	31	30	29	28	27	26	25	24	23	22	21	20	19	18	17	16	15	14	13	12	11	10	9	8	1
P	SSM		CHAR 1			CHAR 2			CHAR 3			CHAR 4			CHAR 5			SDI	LABEL						

Figure 4. Generalized BCD Word Format

32	31	30	29	28	27	26	25	24	23	22	21	20	19	18	17	16	15	14	13	12	11	10	9	8	1
P	SSM		0	1	0	0	1	0	1	0	1	1	1	1	0	0	0	0	1	1	0	SDI		LABEL	
	0	0	2			5			7			8			6										

Figure 5. BCD Word Format Example

BNR Data Encoding

BNR or “binary” encoding is also a very common ARINC data format. This type of encoding simply stores the data as a binary number, much in the same format that is used on virtually every modern-day computer. Figure 6 shows the general BNR format. Bit 29 is the sign bit and bit 28 is the most significant bit of the data field, which represents one half of the maximum value of the parameter being defined. Successive bits represent the increments of a binary fraction series.

32	31	30	29	28	27	26	25	24	23	22	21	20	19	18	17	16	15	14	13	12	11	10	9	8	1
P	SSM	Data														Pad				SDI	LABEL				

Figure 6. Generalized BNR Word Format

Negative numbers are encoded as the two’s complement of positive values. If bit 29 is a ‘1’ then the number is negative (or South, West, Left, From, or Below). Otherwise, it is positive (or North, East, Right, To, or Above).

Figure 7 shows an example of BNR encoding. The particular message uses label 103, which is Selected Airspeed. By referencing the ARINC 429 specification, we know that the scale is 512, and 11 bits are used (29 through 19). A zero in bit 29 shows that this is a positive value. The numeric value is obtained by multiplying the scale factor, determined from data type associated with the label, by the ratio indicated by each successive bit and adding them together. Bit 28 is 1/2 of the scale factor (256 in this case), bit 27 is 1/4 of the scale factor, bit 26 is 1/8 of the scale factor, bit 23 is 1/64, bit 22 is 1/128, etc. Thus, in this example, Selected Airspeed = 268 Knots (256 + 8 + 4).

32	31	30	29	28	27	26	25	24	23	22	21	20	19	18	17	16	15	14	13	12	11	10	9	8	1
P	SSM	Data														Pad				SDI	LABEL				
0	1	1	0	1	0	0	0	0	1	1	0	0	0	0	0	0	0	0	0	0	0	0	0	0	103

Figure 7. Example BNR Encoding

This may appear to be more complex than it really is. The underlying principle is conventional binary mathematics as performed by any modern day computer. A computer programmer can shift the BNR data and sign bits into a program variable and manipulate them directly with any standard mathematical manipulation.

Mixed Formats

The 32-bit message words can also include discrete information, either mixed with BCD or BNR data, or as separate messages. Unused bits in a word may be assigned one bit per variable starting in Bit #11 until the data field is reached. If there are no discretely encoded the word, the unused positions are filled with zeros.

Discrete Data Formats

A large number of ARINC 429 words are dedicated entirely to discretes; these are spelled out in Reference 3. Table 6 shows a word used to transmit engine data.

Table 6. Dedicated Discrete Example

Bit	Function	1	0
1	Label 005	X	
2	Label 005		X
3	Label 005	X	
4	Label 005		X
5	Label 005		X
6	Label 005		X
7	Label 005		X
8	Label 005		X
9	SDI		
10	SDI		
11	PAD		X
12	PAD		X
13	Failure to clear serial data interrupt	Fail	Pass
14	ARINC received fail	Fail	Pass
15	PROM checksum fail	Fail	Pass
16	User RAM fail	Fail	Pass
17	NV RAM address fail	Fail	Pass
18	NV RAM bit fail	Fail	Pass
19	RTC fail	Fail	Pass
20	Microprocessor fail	Fail	Pass
21	Battery low	Fail	Pass
22	NV RAM corrupt	Fail	Pass
23	Not used		
24	Not used		
25	Not used		
26	Interrogate activated		
27	Erase activated	Activated	Non-Act.
28	Bit activated	Activated	Non-Act.
29	SSM	Activated	Non-Act.
30	SSM		
31	SSM		

Bit	Function	1	0
32	Parity (Odd)		

Maintenance Data

ARINC 429 also provides for transmission and acknowledgment of maintenance data and alphanumeric messages. These functions usually involve exchanging a sequence of messages. Alphanumeric messages use ISO Alphabet No. 5. These message types are being superseded by a bit-oriented protocol, which is described later in the tutorial. If you need more information, refer to the specification.

Data Translation Method

Each data item that can be transmitted is assigned a label code, and these are listed in ARINC Specification. Examples of labels are shown in Table 7 for BCD and Table 8 for BNR.

Table 7. Examples of BCD Labels

Label	Equip ID (hex)	Parameter Name	Units	Range Scale	Digits	+	Res.	Min. Tx Rate (Msec)	Max. Tx Rate (Msec)
010	002	Present Position - Latitude	Degrees-Minutes	180N - 180S	6	N	0.1	250	500
	004	Present Position - Latitude	Degrees-Minutes	180N - 180S	6	N	0.1	250	500
	038	Present Position - Latitude	Degrees-Minutes	180N - 180S	6	N	0.1	250	500
014	004	Magnetic Heading	Degrees	0 -359.9	4		0.1	250	500
	005	Magnetic Heading	Degrees	0 -359.9	4		0.1	250	500
	038	Magnetic Heading	Degrees	0 -359.9	4		0.1	250	500

Table 8. Examples of BNR Labels

Label	Equip ID (hex)	Parameter Name	Units	Range (Scale)	Bits	Res.	Min. Tx Rate (Msec)	Max. Tx Rate (Msec)
064	03C	Tire Pressure (nose)	psia	1024	10	1.0	50	250
102	002	Selected Altitude	feet	65536	16	1.0	100	200
	020	Selected Altitude	feet	65536	16	1.0	100	200
	029	DC Current (Battery)	amps	256	8	1.0	100	200
	0A1	Selected Altitude	feet	65536	16	1.0	100	200

Labels may be associated with more than one equipment type, and the equipment IDs associated with the examples are shown in Table 9. Thus BCD label 010 is always present latitude, but it can pertain to three different sources, the Flight Management Computer, the Inertial Reference System, or ADIRS. BCD label 014 is either Magnetic Heading from the Inertial Reference System, Attitude and Heading Reference System, or ADIRS.

Table 9. Equipment IDs for Tables 6 and 7

Equipment ID (Hex)	Equipment Type
002	Flight Management Computer
004	Inertial Reference System
005	Attitude and Heading Reference System
020	DFS System
029	ADDCS and EICAS
038	ADIRS
03C	Tire Pressure Monitoring System
0A1	FCC Controller

In Table 8 BNR label 064 is the nose tire pressure from the Tire Pressure Monitoring System. BNR label 102 can be selected altitude or DC current depending on the equipment ID. Table 7 and Table 8 also show the parameters which identify the units of measure, the range or scale, the significant digits (BCD) or bits (BNR), the positive sense of the quantity, its resolution, maximum and minimum transit interval, and for some labels, the maximum transport delay.

Typically, messages are sent repetitively. For example, measured airspeed is transmitted from the sensor to the instrument at intervals not less than 100 milliseconds or greater than 200 milliseconds. Messages may also be sent in repetitive word sequences or frames. Messages from each fuel tank level sensor are sent in sequence, and then the sequence is repeated after a specified time. The specific data source to which the data applies is determined either by the Label or the SDI.

Table 10 shows label 241, which is transmitted approximately once per second. The sequence shown starts with the left main tank followed by the right and then center. Once the 63-word sequence is completed, it repeats, starting over with word 1. Most of the data is in BNR format, but some words are in BCD.

Table 10. Message Sequence for Label 241

Word	Signal	Units	Range	Sig. Digits	Resolution	Data
1	Left Main Tank #1	pF	319.922	12	.078125	BNR
2-13	Left Main Tanks #1 to #13	pF	319.922	12	.078125	BNR
14	Left Main Tank #14	pF	319.922	12	.078125	BNR
15	Left Main Bite Cap. No. 1	pF	319.922	12	.078125	BNR
16	Left Main Compensator	pF	319.922	12	.078125	BNR
17	Load Select 10,000	Lb.	0-90000	1	10,000	BCD
18	Load Select 1,000	Lb.	0-9000	1	1,000	BCD
19	Load Select 100	Lb.	0-900	1	100	BCD
20	No Data Transmitted					
21	Left Main Fuel Density	Lb./Gal	8,000	12	.000977	BNR
22-42	Repeat Words 1-21 for Right Tanks					
43-53	Repeat Words 1-21 for Center Tanks					
54-58	No Data Transmitted					
59	Load Select 10,000	Lb.	0-90000	1	10,000	BCD
60	Load Select 1,000	Lb.	0-9000	1	1,000	BCD
61	Load Select 100	Lb.	0-900	1	100	BCD
62	No Data Transmitted					
63	Center Tank Density	Lb./Gal	8,000	12	.000977	BNR

Bit Oriented Protocols

The Williamsburg, or "bit oriented", Protocol is a system for transferring files between ARINC units. It was originally defined in ARINC Specification 429-12 and expanded in Specifications 429-13 and 14 and is further defined in Reference 5. It is currently under revision. It should be used in lieu of the former AIM, file transfer, and maintenance formats used in Specification 429-11. Normal ARINC data messages can be intermixed with the bit-oriented messages of the Williamsburg Protocol.

A start up procedure is used to determine the proper protocol for transferring data. When a system element wants to use the bit-oriented system it transmits a message using the latest version of which it is capable. A handshaking process adjusts the protocol to the lowest common denominator that both sending and receiving systems can use. Currently, two versions of the Protocol are available. Version 1 is defined in 429-12 and refined in 429-13. Version 2 is defined in 429-14 but was never used. Reference 5 deletes Version 2 and it defines a new Version 3. It redefines Version 1 to facilitate the communications of the ACARS Management Unit (MU) and the Satellite Data Unit (SDU).

The source initiates communications by sending certain predefined codes. If a bit-oriented transfer is desired, the initial code word will be an "ALO" (for Aloha) signal to the potential recipient. The ALO word should be sent by any system that supports the protocol just after the system powers up, or performs a re-initialization for any reason. If any sink is capable of receiving bit-oriented data it responds with an "ALR" code so that the source knows that it can transmit to that unit. When a source wants to transmit to a unit capable of handling the protocol, it sends a Request to Send word (RTS), and waits to receive a Clear to Send (CTS). The RTS includes a Destination Code and a Word Count, which are repeated in the CTS for verification. If the CTS is correct, the source then initiates the file transfer, following the sequence shown in Figure 8 for version 1. The latter version provides the capability of sending a larger file (up to 7 LDUs), without needing to renew permission of the sink.

Files are transferred in blocks called Link Data Units (LDU) ranging in size from 3 to 255 words. Following receipt of the CTS, the source initiates a Version 1 transfer with a Start of Transmission word (SOT). The SOT includes a file sequence number, a General Format Identifier (GFI), and a LDU Sequence Number. The data words are then sent, followed by the (up to) 255th word which is an End of Transmission (EOT). Each LDU transfer (255 words or less) is terminated by an End of Transmission Word (EOT). The EOT includes a CRC and identifies the position of the LDU in the overall file transfer. The sink performs a verification process on the EOT, and sends an Acknowledgment Word (ACK) if all tests are passed. The source then sends another CTS, and the process is repeated until the last LDU is acknowledged.

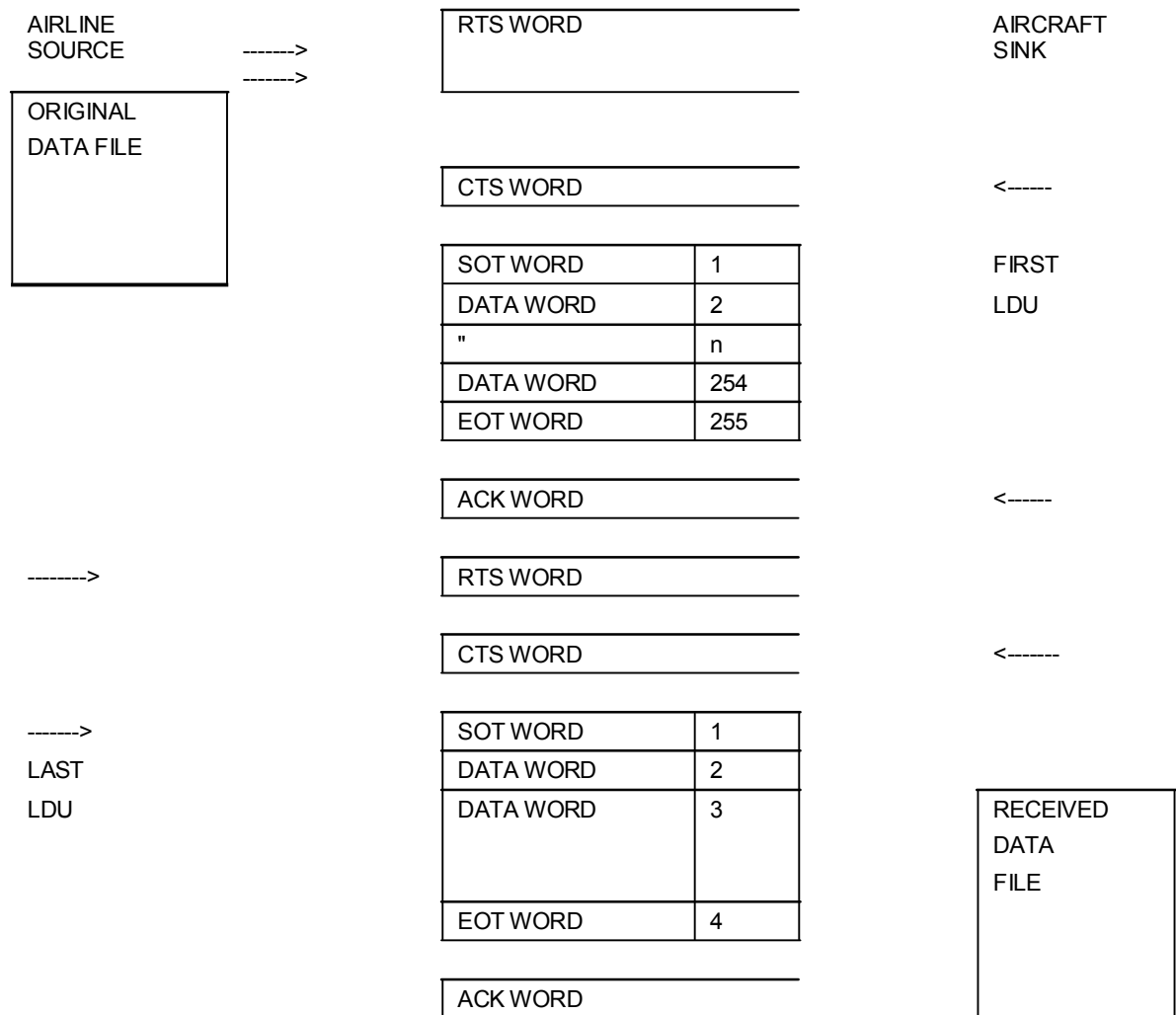

Figure 8. File Transfer Scheme Version 1 (no Windows)

Table 11. Systems Using Bit Oriented Communications and Their Address Labels

SYSTEM	SAL (OCT)	SYSTEM	SAL (OCT)
777 CABIN INTERPHONE SYSTEM	152	LOW SPEED DATA LINK (ARINC 603)	300
747 DFDR AND A330/340 SSFDR	163	FMC 1	300
DFDAU (Mandatory Load Functions)	170	FMC 2	301
SDU #2	173	DFDAU (AIDS)	302
RFU	174	CFDIU	303
HGA/HPA TOP/PORT	175	ACARS MU/CMU (724B, 748)	304
HGA/HPA STARBOARD	176	WBS	305
LG/HPA	177	TCAS	306
GPS/GNSS SENSOR	201	SDU #1	307
MCDU 1	220	CABIN TELECOMMUNICATIONS UNIT (CTU)	334
MCDU 2	221	HF DATA RADIO/DATA UNIT #1	340
MCDU 3	222	HF DATA RADIO/DATA UNIT #2	344
PRINTER 1	223	ACCESS	360
PRINTER 2	224	EFIS	361
HIGH SPEED DL (ARINC 615)	226	ENGINE INDICATION UNIT	365
MCDU 4	230	CABIN TERMINAL 3	372
EIVMU 1	234	CABIN TERMINAL 4	373
EIVMU 2	235	CABIN TERMINAL 1	374
EIVMU 3	236	CABIN TERMINAL 2	375
EIVMU 4	237	OMEGA NAV. SYSTEMS	376
CABIN VIDEO SYSTEM (AIRSHOW)	266		

ARINC 429 Testing

Test Equipment

ZHHKTECH provides product solutions to fill a great majority of ARINC429 marketplace needs. Such as the ARINC 429 test and simulation board card products, Arinc-429 interface cards, Arinc429 interface modules, Arinc-429 bus tester, etc.

The ZHHKTECH *ZHHK429-PCI*, *ZHHK429-CPCI*, *ZHHK429-PXI*, *ZHHK429-USB*, *ZHHK429-PCMCIA*, *ZHHK429-PC104*, *ZHHK429-ISA* hardware platforms support:

Supported computer bus platform:

ISA, PC104, PCI, CPCI, PXI, VME, PMC, USB.

Supported transmit and receive channel for: 1Tx, 2Rx ; 2Tx, 2Rx ; 2Tx, 4Rx ; 4Tx, 4Rx ; 4Tx, 8Rx ; 8Tx, 8Rx .

Four Speeds : 12.5K, 48K, 50K, 100K, Programmable settings

Software to set the depth of FIFO trigger

Optional interrupt and query method

Each transmit and receive channels are configured large-capacity FIFO

Label Filter

Timing sent

Driver: provides a standard DLL, supports VC, VB, Delphi, LabVIEW, CVI and other standard development language

Applications: just install the ARINC 429 card can be used to achieve most applications operating functions required for communication

Technical Specifications:

Power Requirements: +5VDC, 12VDC

Operating temperature: -40 to +85 deg C

Physical Dimensions: CPCI as a 3U, other boards for the standard model

Connector: PC/104 bus with double the non-pin connector, other optional DB25, DB62, SCSI36, SCSI68 and so on, comes standard with a corresponding connector joints

For more information on these products, please contact ZHHKTECH sales,

TEL: 86-29-84288198 E-mail: sales@zhktech.com WEB: www.zhktech.com

Other ARINC Protocols

ARINC 419

Reference 7, ARINC 419 Digital Data System Compendium, describes a number of digital transmission system building blocks which were available prior to 1984. It provides a synopsis of many protocols that predate ARINC 429 such as ARINC 561, 582, 573 and 575.

The reference describes a number of digital transmission systems with varying standards. Some systems used 32-bit words similar to ARINC 429; some used major frames of four subframes each consisting of 64, 12-bit words. Still others used 32-bit, rather than 64-bit words. Some message frames were 24 bits with three subframes of two BCD words. Some systems did not provide information identifiers; others used 8-bit label codes, and another depended on time slots for identifying information. Identification of BCD vs. BNR was provided by a flag bit in either the 1st bit or the 4th bit transmitted. A variety of standard data labels were adopted.

Some electrical interconnections depended on one wire per bit; others used the 6 wire system described above while others used a shielded 2 wire twisted pair or a coaxial cable. Either two state, (HI LO), or three state (HI NULL LO) were used. Voltage levels ranged from 18.5 to 10 for the high state and from (less than) 5 to 1 for the null where used. Digital languages included Gilham code (an example is the altitude encoder for the ATC Transponder), a bit stream you determined in each individual case, International Standards Organization (ISO) Alphabet #5, BCD, and BNR. In some cases there was no error detection or correction, others used bit parity or character parity, or block sequence check. Bit rate varied from 384 BPS to 12+ KBPS, and there were many other variations among systems.

The variability of “standards” doesn’t matter where a single user is involved, but is very important when equipment from different suppliers must interact with each other. Standardization is beneficial not only to the aircraft integrator, but to the equipment supplier who can have greater assurance of product acceptability so long as it is “on spec”. ARINC 429

is the most widely applied Digital Data Transmission specification for modern transport aircraft. ARINC 429 draws on the experience of 419 but does not depend on it.

ARINC 453

Not a formally released specification. See ARINC 708.

ARINC 561/568

The need for standardized digital data transmission arose during the development of ARINC Characteristics 561, “Air Transport Inertial Navigation System”. ARINC 568 uses the same electrical interface as ARINC 561.

A six-wire system involving 3 pairs of wires, was used in 561. The three pairs served as “clock”, “sync”, and “data” respectively. Non return to zero (NRZ) was employed, and a twelve-volt logic level was transmitted for a binary 1. The word length was 32 bits. Bits 32 and 31 contained the SSM, and no parity bit was provided. The remaining fields included an 8-bit label and 6 BCD fields, five of 4 bits and one of 2 bits. In 1967 the six-wire system was adopted as an industry standard.

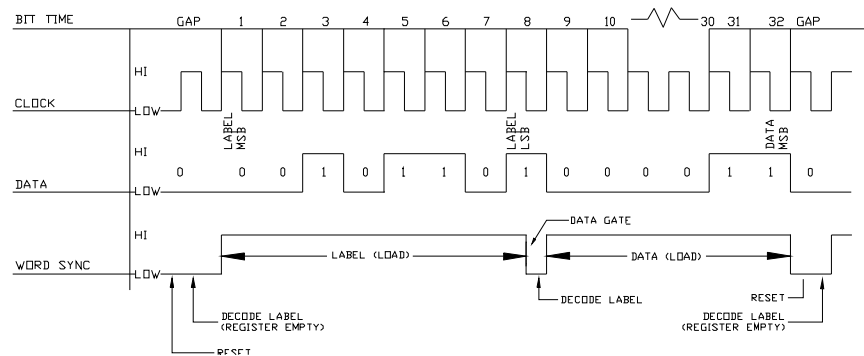

Figure 9. ARINC 561 6-Wire Bit Encoding

ARINC 573

Other standards include ARINC 573, a Flight Data Recorder output format. This device sends a continuous data stream of Harvard Bi-Phase encoded 12 bit words which is encoded in frames. The data in a frame consists of a snapshot of the many avionics subsystems on the aircraft. Each frame contains the same data at a different snapshot in time.

Each frame is broken into four sub-frames. At the start of each sub-frame is a unique sync word that is used by the receiver to synchronize with the incoming data.

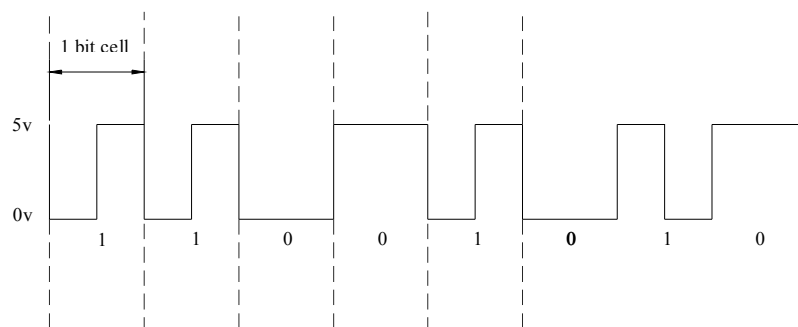

Figure 10. Harvard Bi-phase Bit Encoding

ARINC 575

ARINC 575 is an older specification very similar to ARINC 429 but now obsolete. It accommodated the Mark 3 Subsonic Air Data System (DADS) with a single twisted pair of wires, which has become the standard in ARINC 429. Electrically, ARINC 575 is generally compatible with low speed ARINC 429. Some variants of 575 use a bit rate that is significantly slower than ARINC 429 and are not electrically compatible. Also, in some cases, ARINC 575 words use bit 32 as parity (as does ARINC 429); in other cases bit 32 is used as data.

ARINC 582

This is an older specification that has many electrical permutations. There are 6-wire versions (see ARINC 561), 2-wire versions (see ARINC 575) as well as 16-bit, 2-wire versions.

ARINC 615

Special cases of ARINC 429 compliant systems also exist. ARINC 615 (See Reference 8) describes a high-speed data loader to transfer information to and from on board digital systems. It is a software protocol layered on top of an ARINC 429 physical layer. There are two versions of the loader. PDL is a portable flight line piece of test equipment and ADL is designed to fit in commercial aircraft instrument panels. Both equipment are capable of reading and writing to 3½ inch diskettes and transferring

data between the diskettes and a selected airborne computer. The transfers can occur automatically, or via an ARINC 429 data bus. Data can be either uploaded or downloaded as desired.

ARINC 629

Additional ARINC standards are being developed. ARINC 629 is used on the new Boeing 777 Aircraft. It uses a high-speed bi-directional bus capable of either periodic or aperiodic transmissions. Access to the bus is controlled by a sophisticated protocol involving wait periods, quiet periods and other rules. Further details can be found in Reference 9.

ARINC 708

This protocol is specific to airborne weather radar systems. It is used as the output from the radar to the radar display. The bus uses 2-wires, is simplex, Manchester encoded and runs at a one-megabit data rate. It was originally based upon a simple derivative of MIL-STD-1553 technology. The data words are 1600 bits long which is composed of one, 64-bit status word and 512, 3-bit data words.

ARINC 717

ARINC 717 supercedes ARINC 573 and is used to perform the same function. It adds a number of different bit rates and frame sizes. It also provides for an alternate output data stream that is identical to the primary, Harvard Bi-phase encoded stream, except that it is encoded in BPRZ format (the same as ARINC 429).

References

List of References

- .. ARINC Web Site, <http://www.arinc.com>
- .. ARINC Specification 429P1-15, September 1, 1995
- .. ARINC Specification 429P2-15, March 6, 1996
- .. “Principles of Avionics Data Buses”, Editorial Staff of Avionics, Communications Inc., Leesburg, VA
- .. AEEC Letter 97-013/WIL-03, January 24, 1996
- .. ARINC Digital Data System Compendium, ARINC Report 419-3, November 5, 1984
- .. ARINC Airborne Computer Data Loader, ARINC Report 615-2, June 1, 1991
- .. “ARINC 629 P1-4 Multi-Transmitter Data Bus”, “Part1, Technical Description”, December, 1995
- .. Aeronautical Radio, Inc., 2551 Riva Road, Annapolis, MD, 21401
- .. Global Engineering Documents